

Hydraulik-Kurzhubzylinder HKZ 500

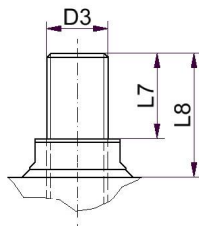

Kolbenstangenende X1
Mit eingesetztem
Gewindestift,
ab M20 Kolbenstange
mit Aussengewinde

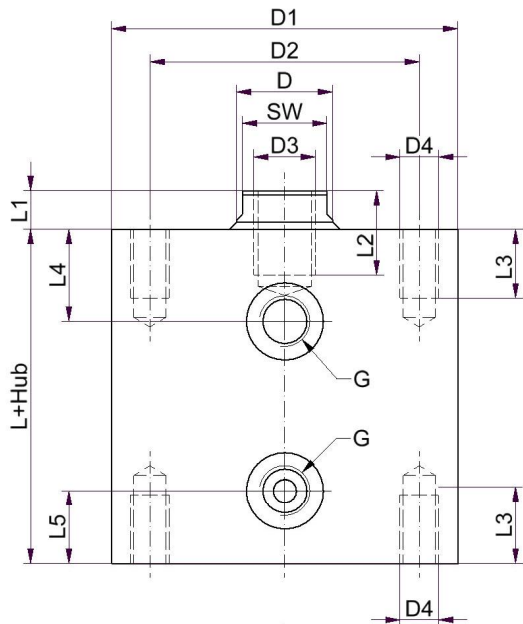
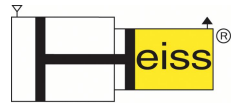
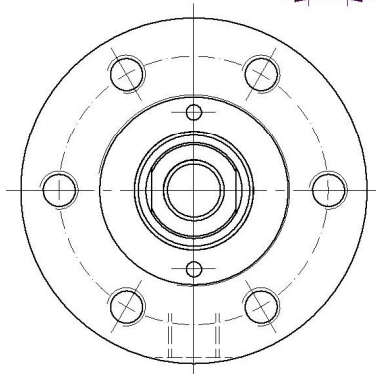
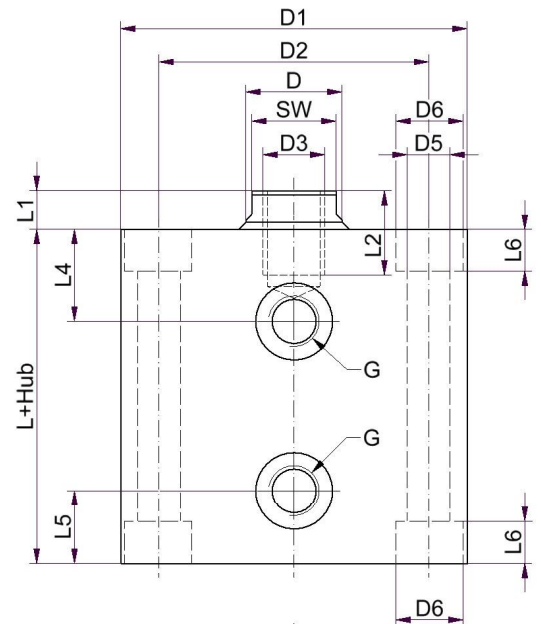

Ausführung A
4 bzw. 6 beidseitige
Gewindesacklochbohrungen

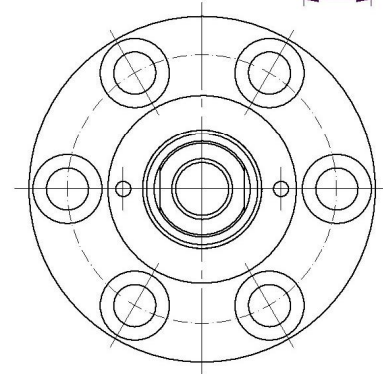

Ausführung B
4 bzw. 6 Durchgangsbohrungen
mit beidseitigen Senkung für
Zylinderkopfschrauben DIN 912

Kolben-ø	16	20	25	32	40	50	63	80	100	125	160	200
D Kst ø	10	12	16	20	25	32	40	50	60	80	100	125
Normhub	16	16	20	25	25	25	30	30	40	40	40	40
L	50	52	54	58	62	72	82	97	100	120	140	170
G	G1/4"	G1/4"	G1/4"	G1/4"	G1/4"	G1/4"	G1/2"	G1/2"	G1/2"	G1/2"	G1/2"	G3/4"
D1	60	60	65	75	90	100	125	160	200	240	310	360
D2	44	46	50	58	70	80	100	130	160	190	250	290
D3	M6	M8	M10	M12	M16	M20	M27	M30	M42	M48x2	M56x2	M70x2
D4	4xM6	4xM6	6xM6	6xM8	6xM10	6xM10	6xM12	6xM16	6xM20	6xM24	6xM30	6xM36
D5	4xø6,5	4xø6,5	6xø6,5	6xø9	6xø11	6xø11	6xø13,5	6xø17,5	6x ø22	6xø25	6xø32	6xø39
D6	11	11	11	15	18	18	20	26	33	40	48	57
L1	6	7	7	10	10	10	14	14	15	16	22	28
L2	15	15	15	25	30	35	40	40	55	60	70	85
L3	15	15	15	18	18	20	20	25	30	35	45	55
L4	17	20	19	22	25	27	28	35	37	51	55	65
L5	17	17	17	19	19	19	23	25	25	25	35	40
L6	7	7	7	9	11	11	13	17,5	21,5	25,5	32	38
L7	15	15	15	20	20	20	25	30	35	40	45	55
L8	21	22	22	30	30	30	39	44	50	56	67	83
SW	8	10	14	17	22	30	36	46	55	75	95	115

Technische Änderungen vorbehalten

Revision B * 20.03.13