

Hydraulik - Gelenkköpfe CGKA

- nach DIN 24555 -

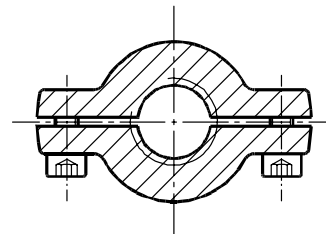
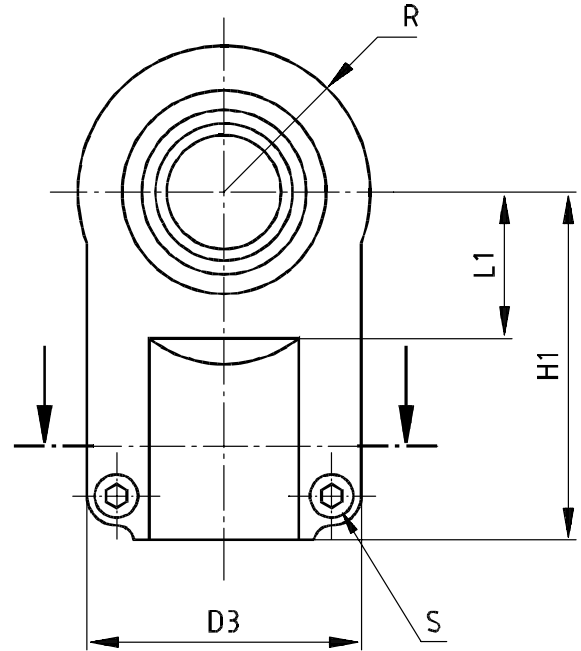
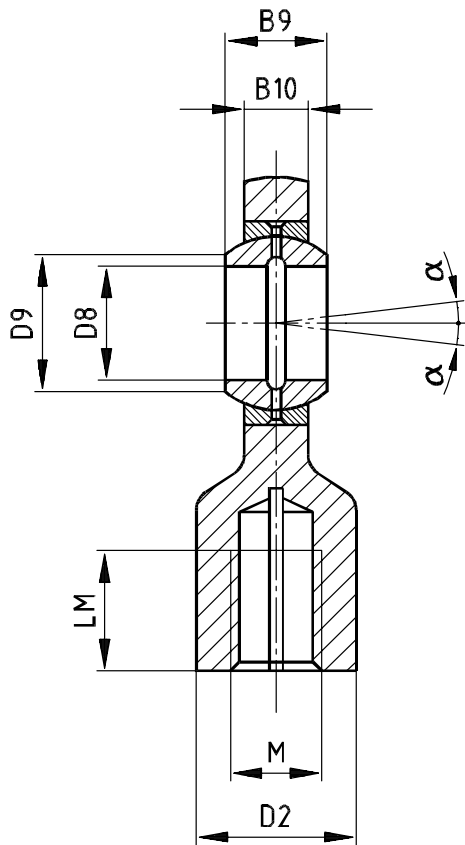
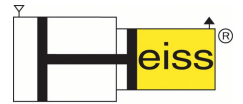

Bezeichnung	Maße:											Tragzahlen:		Zylinderschraube	Gewicht		
	D8H8	D9	B9	B10	M	LM	H1	R	D2	D3	L1	α	C	C0	S	MA	G
	[mm]											[°]	[kN]		DIN912-8.8	[Nm]	[kg]
CGKA 12	12	15	10	8	M10x1,25	15	42	17	17	35	16	11	10,8	17,0	M6	12,0	0,12
CGKA 16	16	20	14	11	M12x1,25	17	48	22	21	45	20	10	21,1	28,5	M6	12,0	0,23
CGKA 20	20	24	16	13	M14x1,5	19	58	27	25	55	28	9	30,0	42,5	M8	30,0	0,41
CGKA 25	25	29	20	17	M16x1,5	23	68	32	30	62	31	7	48,0	67,0	M8	30,0	0,66
CGKA 30	30	34	22	19	M20x1,5	29	85	40	36	77	35	6	62,0	108,0	M10	59,0	1,2
CGKA 40	40	45	28	23	M27x2	37	105	50	45	90	45	7	100,0	156,0	M10	59,0	2,1
CGKA 50	50	55	35	30	M33x2	46	130	60	55	105	58	6	156,0	245,0	M12	100,0	3,8
CGKA 60	60	67	44	38	M42x2	57	150	80	68	134	68	6	245,0	380,0	M16	250,0	7,7
CGKA 80	80	90	55	47	M48x2	64	185	102	90	156	92	6	400,0	585,0	M20	490,0	15,1
CGKA 100	100	110	70	57	M64x3	90	240	120	110	190	116	6	610,0	865,0	M24	840,0	27,5

Technische Änderungen vorbehalten

Revision B * 30.04.2014 *K.E.*\..Zubehör_german