

Hydraulic Kompakt Cylinder HKZ 160

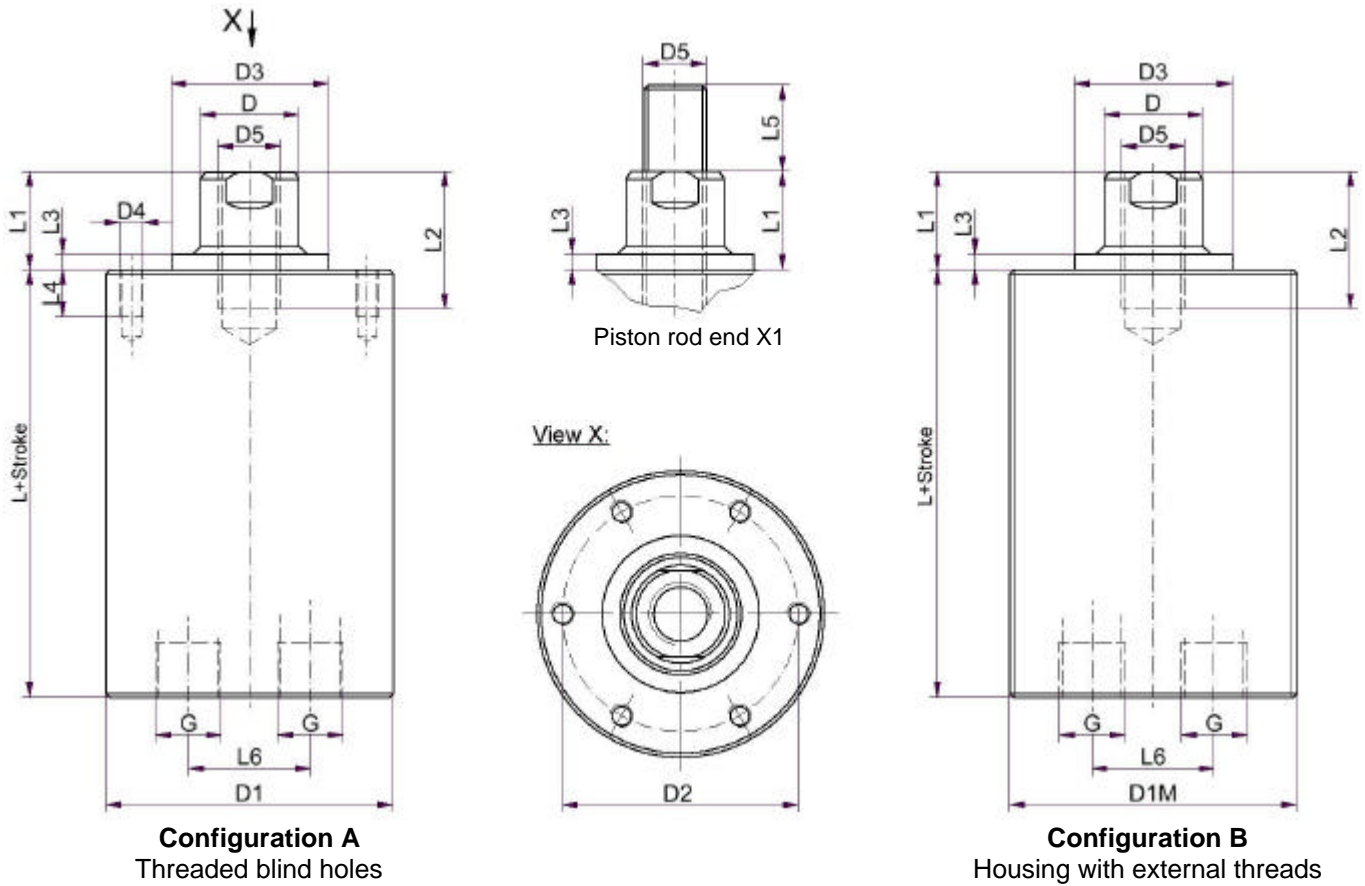

Piston-ø	D	Nom. stroke	L	G	D1	D1M	D2	D3 f7	D4	D5	L1	L2	L3	L4	L5	L6
25	12	10	55	G1/8"	42	M42x1,5	32	25	M4	M8	10	15	3	7	15	18
32	16	15	65	G1/4"	52	M52x2	40	30	M5	M10	12	15	3	8	20	24
40	20	15	75	G1/4"	65	M65x2	50	36	M6	M12	15	20	3	10	22	28
50	25	20	89	G3/8"	75	M75x2	60	40	M6	M16	20	25	4	12	25	31
63	32	20	106	G3/8"	95	M95x2	73	50	M8	M20	25	30	5	14	30	43
80	40	20	155	G1/2"	120	M120x2	80	60	M10	M24	25	30	5	20	40	60

Attachment accessories:

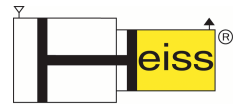
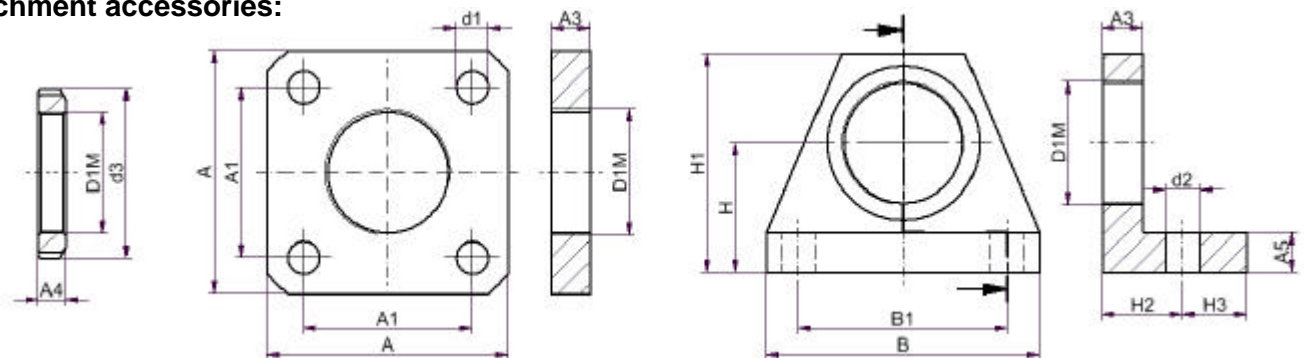

Grooved nut Order.No.98

Rect.-flange Oder.No.112

Angled foot Order.No.113

Piston-ø	A	A1	A3	A4	A5	B	B1	H	H1	H2	H3	d1	d2	d3	Piston rod end X1 With inserted threaded pin, starting at M20 piston rod with male thread
25	90	62	14	9	10	100	70	38	68	30	20	11	13	58	
32	100	70	16	11	12	120	85	50	80	35	25	13	17,5	70	
40	110	80	20	12	20	135	100	60	95	40	30	13	17,5	85	
50	130	96	25	13	25	170	130	75	120	50	35	17,5	21,5	98	
63	150	115	35	17	30	215	165	90	140	60	40	17,5	21,5	125	
80	160	125	35	20	35	230	180	105	165	70	55	17,5	26	155	

Design subject to change

Revision B * 11.04.13